

Pläne Haus 1

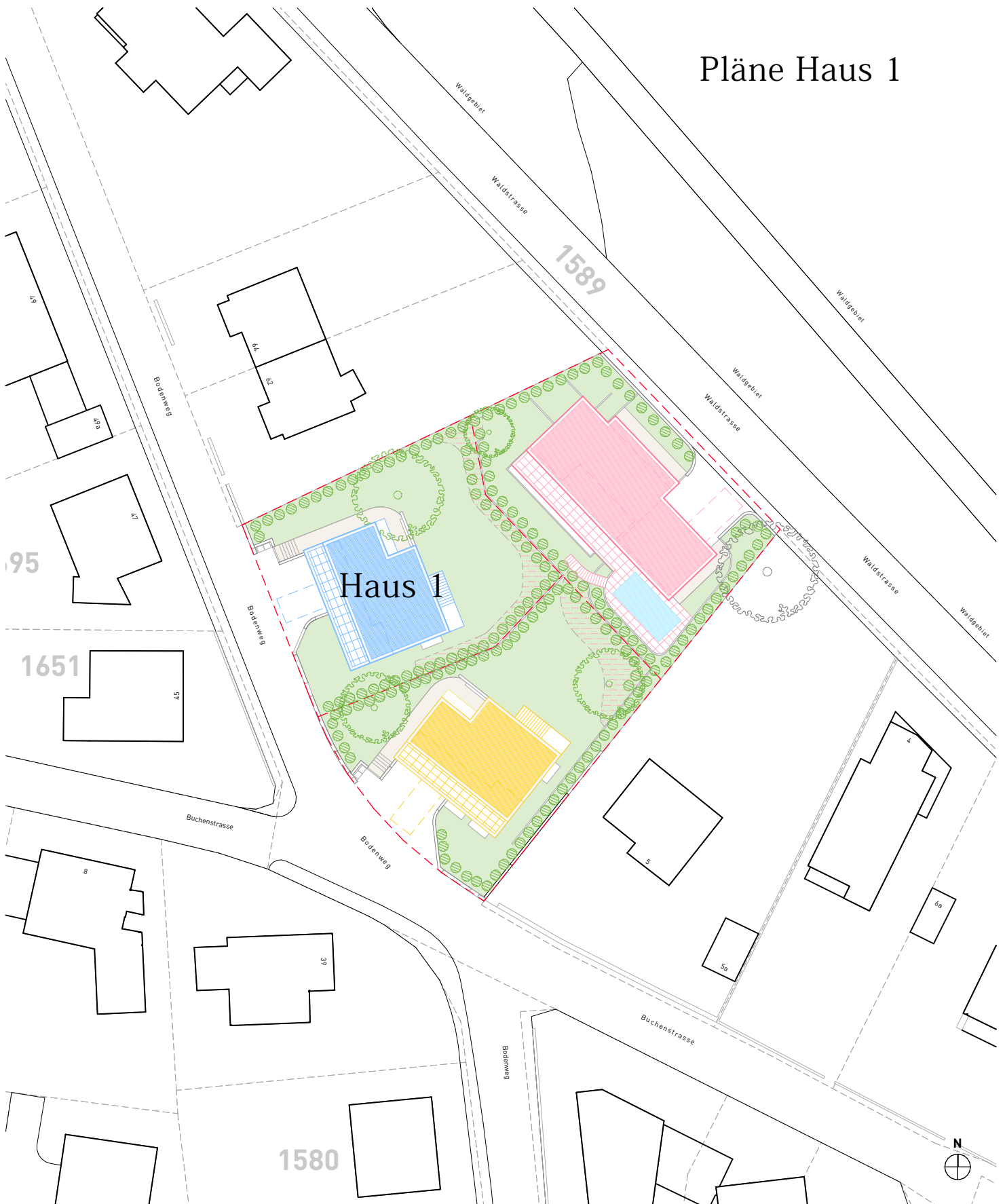

HAUS 1 | BODENWEG 60
HAUS 2 | BODENWEG 62
HAUS 3 | WALDSTRASSE 02

SWISSNESS INVEST AG HOLBEINSTRASSE 95 CH-4051 BASEL	
PROPLANING AG TÜRKHEIMERSTRASSE 6 PF CH-4009 BASEL	
VERKAUF IMMOOFFICE, HOLBEINSTRASSE 95 CH-4051 BASEL	
1306-00-3 BOD PARZELLE 1603 BODENWEG 60 CH-4144 ARLESHEIM	
NEUBAU, DREI EFH	
SITUATION 1:500	
1:500	A4
SIT.001	07.11.2025

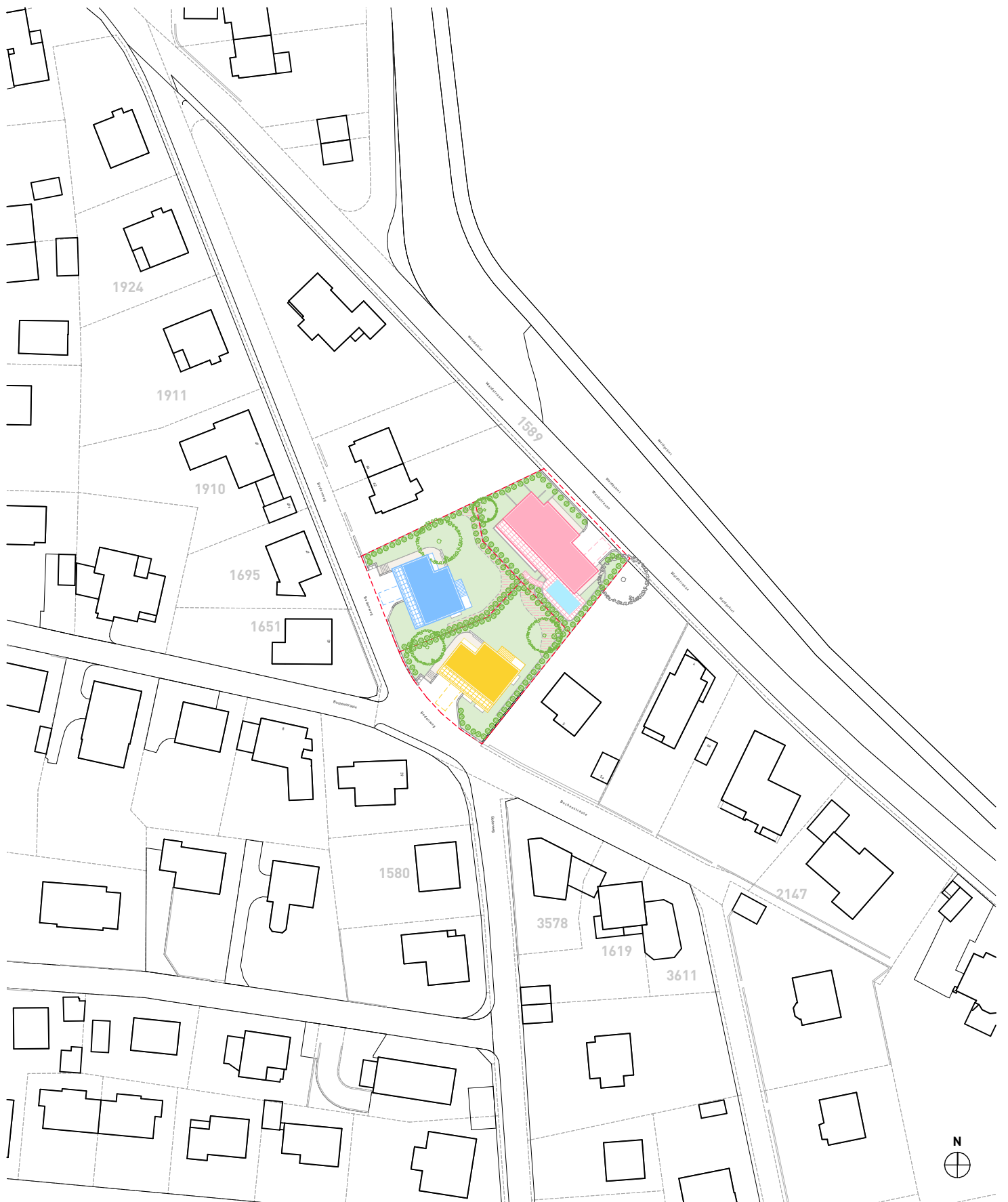

HAUS 1 | BODENWEG 60
HAUS 2 | BODENWEG 62
HAUS 3 | WALDSTRASSE 02

SWISSNESS INVEST AG HOLBEINSTRASSE 95 CH-4051 BASEL	
PROPLANING AG TÜRKHEIMERSTRASSE 6 PF CH-4009 BASEL	
VERKAUF IMMOOFFICE, HOLBEINSTRASSE 95 CH-4051 BASEL	
1306-00-3 BOD PARZELLE 1603 BODENWEG 60 CH-4144 ARLESHEIM	
NEUBAU, DREI EFH	
SITUATION 1:1000	
1:1000	A4
SIT.002	07.11.2025

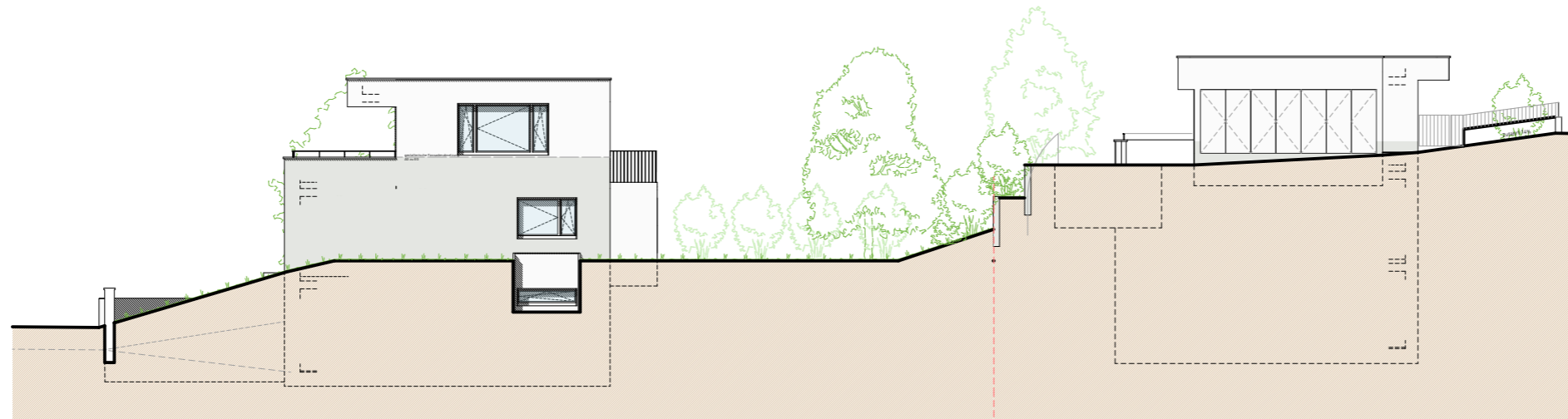

ANSICHT SÜED
(BEGRADIGT)

HAUS 2

HAUS 3



ANSICHT WEST
(BEGRADIGT)

HAUS 1

HAUS 2

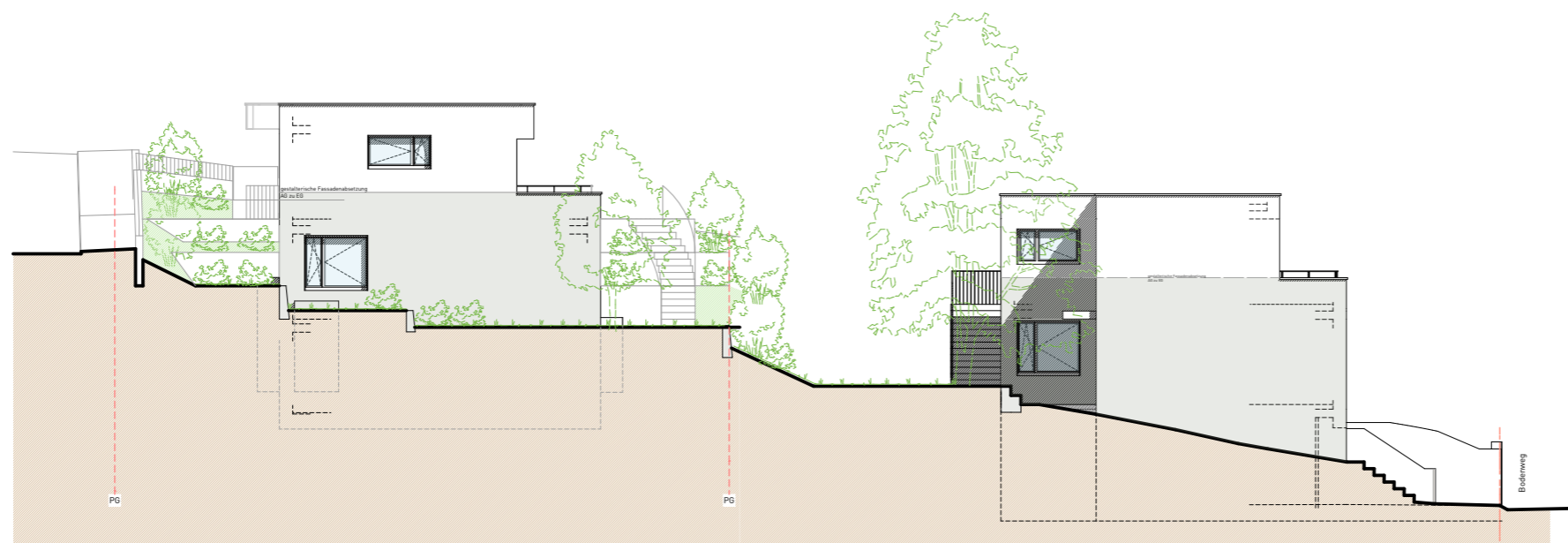

ANSICHT NORD
(BEGRADIGT)

HAUS 3

HAUS 1

HAUS 1 | BODENWEG 60
 HAUS 2 | BODENWEG 62
 HAUS 3 | WALDSTRASSE 02

0 2 4 6 8 10

SWISSNESS INVEST AG HOLBEINSTRASSE 95 CH-4051 BASEL	
PROPLANING AG TÜRKHEIMERSTRASSE 6 PF CH-4009 BASEL	
VERKAUF IMMOOFFICE, HOLBEINSTRASSE 95 CH-4051 BASEL	
1306-00-3 BOD PARZELLE 1603 BODENWEG 60 CH-4144 ARLESHEIM	
NEUBAU, DREI EFH	
ANSICHTEN ÜBERSICHT	
1:200	A3
SIT.003	07.11.2025

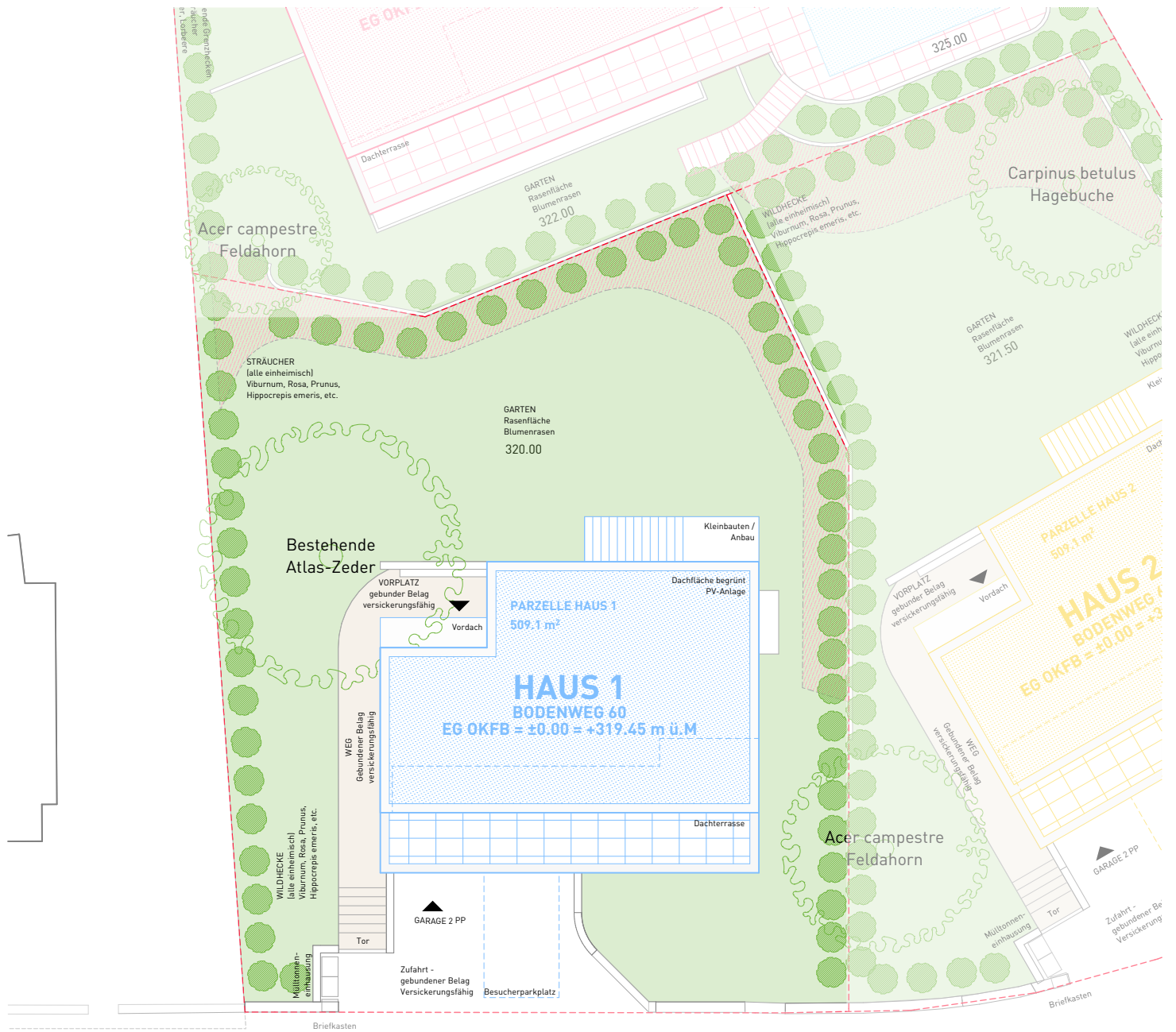

Bodenweg

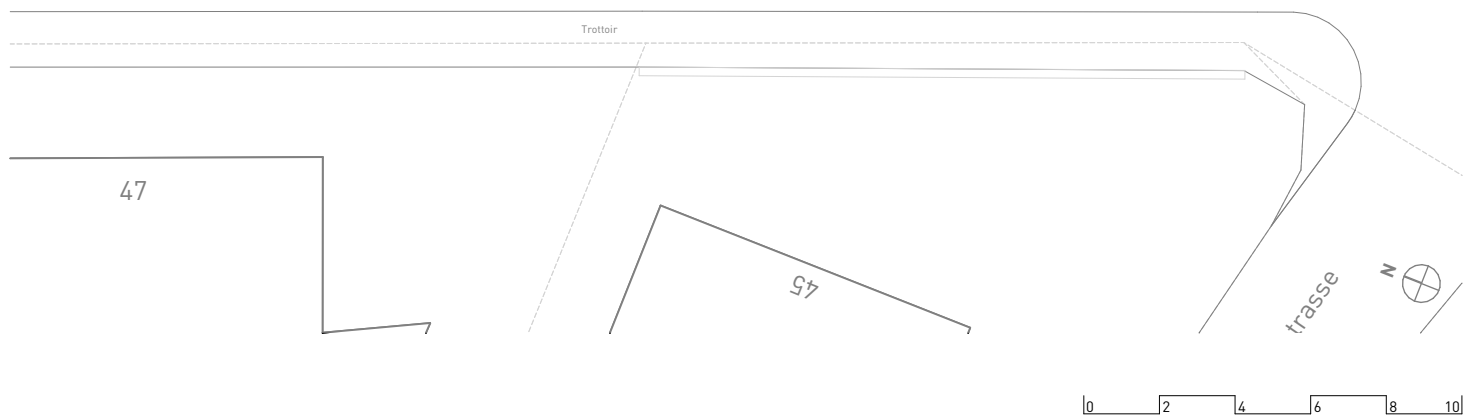

HAUS 1 | BODENWEG 60
 HAUS 2 | BODENWEG 62
 HAUS 3 | WALDSTRASSE 02

SWISSNESS INVEST AG HOLBEINSTRASSE 95 CH-4051 BASEL	
PROPLANING AG TÜRKHEIMERSTRASSE 6 PF CH-4009 BASEL	
VERKAUF IMMOFFICE, HOLBEINSTRASSE 95 CH-4051 BASEL	
1306-00-3 BOD PARZELLE 1603 BODENWEG 60 CH-4144 ARLESHEIM	
NEUBAU, DREI EFH HAUS 1	
UMGEBUNG	
1:200	A4
H1.002	07.11.2025

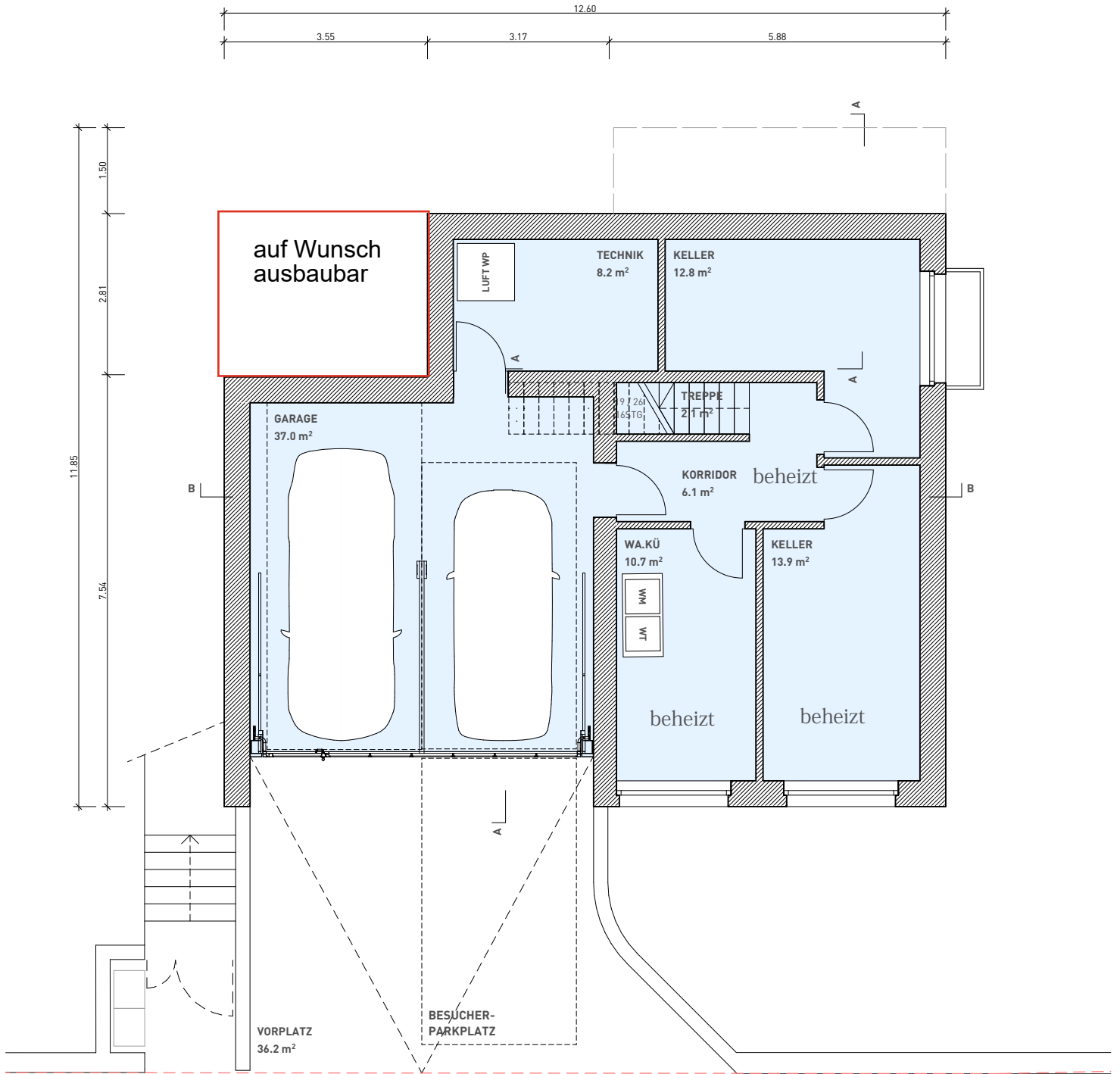

BODENWEG

Fahrbahn



Trottoir

- HAUS 1 | BODENWEG 60**
- HAUS 2 | BODENWEG 62
- HAUS 3 | WALDSTRASSE 02

SWISSNESS INVEST AG HOLBEINSTRASSE 95 CH-4051 BASEL	
PROPLANING AG TÜRKHEIMERSTRASSE 6 PF CH-4009 BASEL	
VERKAUF IMMOFFICE, HOLBEINSTRASSE 95 CH-4051 BASEL	
1306-00-3 BOD PARZELLE 1603 BODENWEG 60 CH-4144 ARLESHEIM	
NEUBAU, DREI EFH HAUS 1	
UNTERGESCHOSS	
1:100	A4
H1.003	07.11.2025

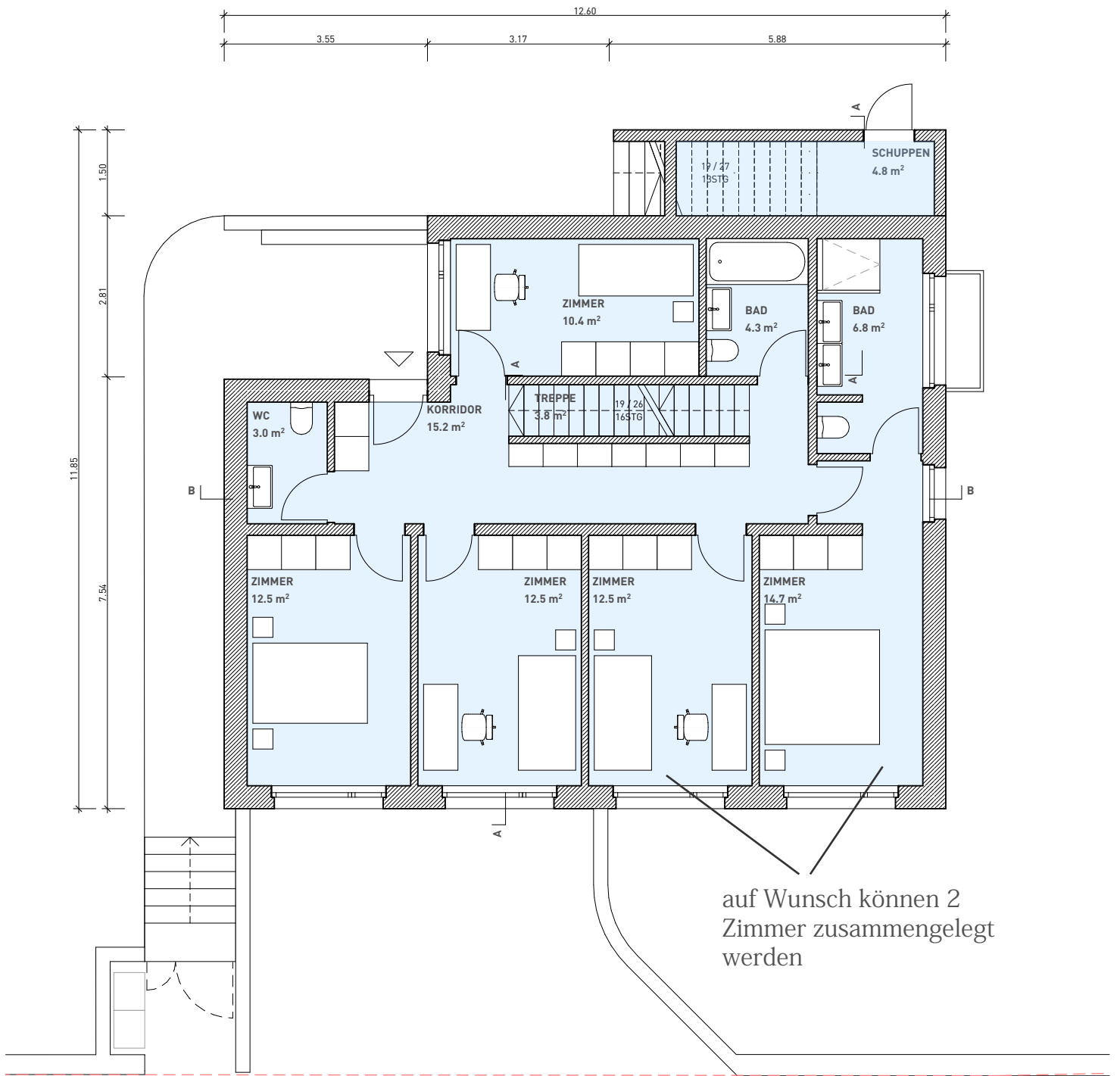

BODENWEG

Fahrbahn



Trottoir



HAUS 1 | BODENWEG 60
 HAUS 2 | BODENWEG 62
 HAUS 3 | WALDSTRASSE 02

SWISSNESS INVEST AG HOLBEINSTRASSE 95 CH-4051 BASEL	
PROPLANING AG TÜRKHEIMERSTRASSE 6 PF CH-4009 BASEL	
VERKAUF IMMOOFFICE, HOLBEINSTRASSE 95 CH-4051 BASEL	
1306-00-3 BOD PARZELLE 1603 BODENWEG 60 CH-4144 ARLESHEIM	
NEUBAU, DREI EFH HAUS 1	
ERDGESCHOSS	
1:100	A4
H1.004	07.11.2025

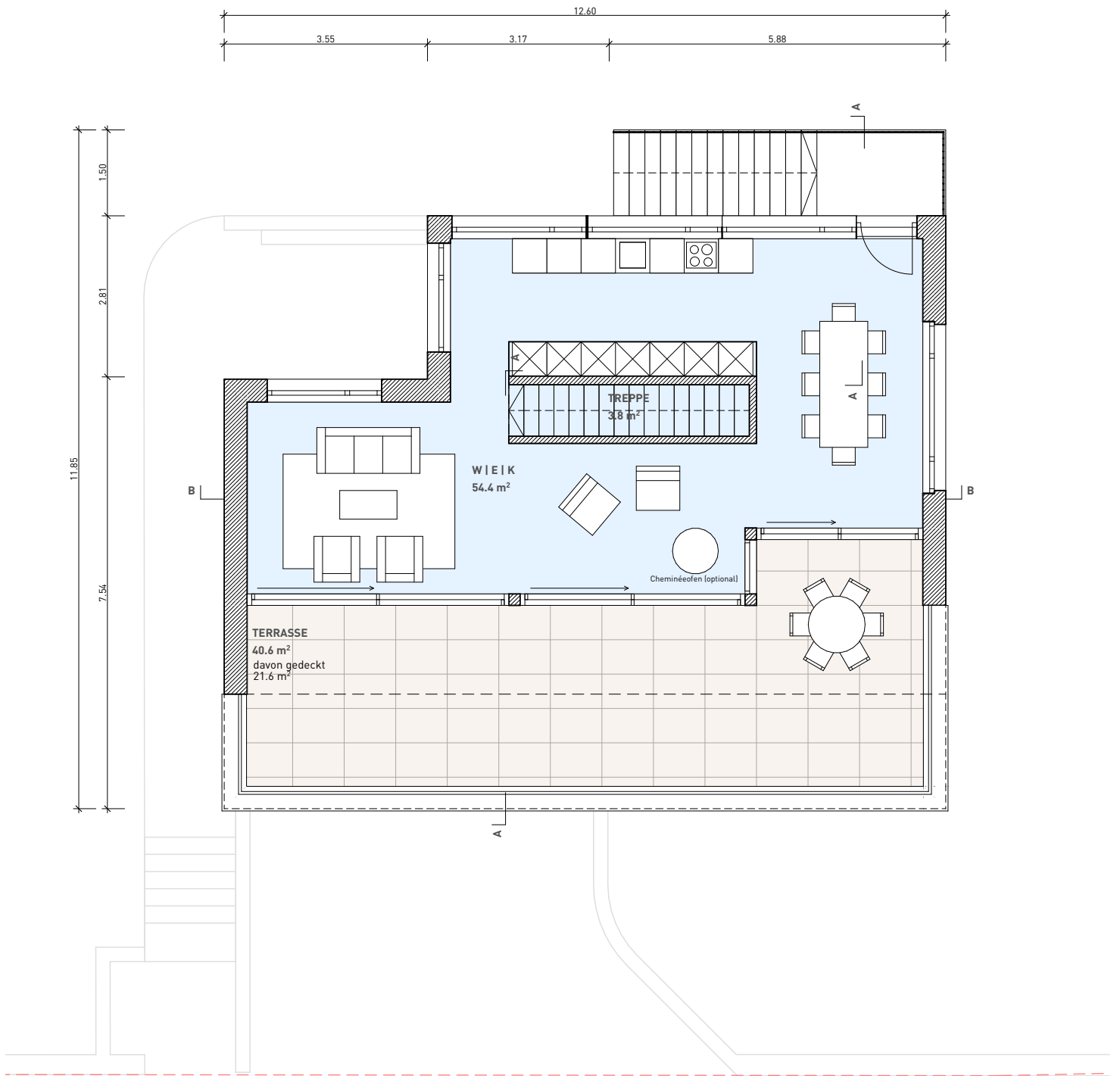

BODENWEG

Fahrbahn



HAUS 1 | BODENWEG 60
 HAUS 2 | BODENWEG 62
 HAUS 3 | WALDSTRASSE 02

SWISSNESS INVEST AG HOLBEINSTRASSE 95 CH-4051 BASEL	
PROPLANING AG TÜRKHEIMERSTRASSE 6 PF CH-4009 BASEL	
VERKAUF IMMOFFICE, HOLBEINSTRASSE 95 CH-4051 BASEL	
1306-00-3 BOD PARZELLE 1603 BODENWEG 60 CH-4144 ARLESHEIM	
NEUBAU, DREI EFH HAUS 1	
ATTIKAGESCHOSS	
1:100	A4
H1.005	07.11.2025

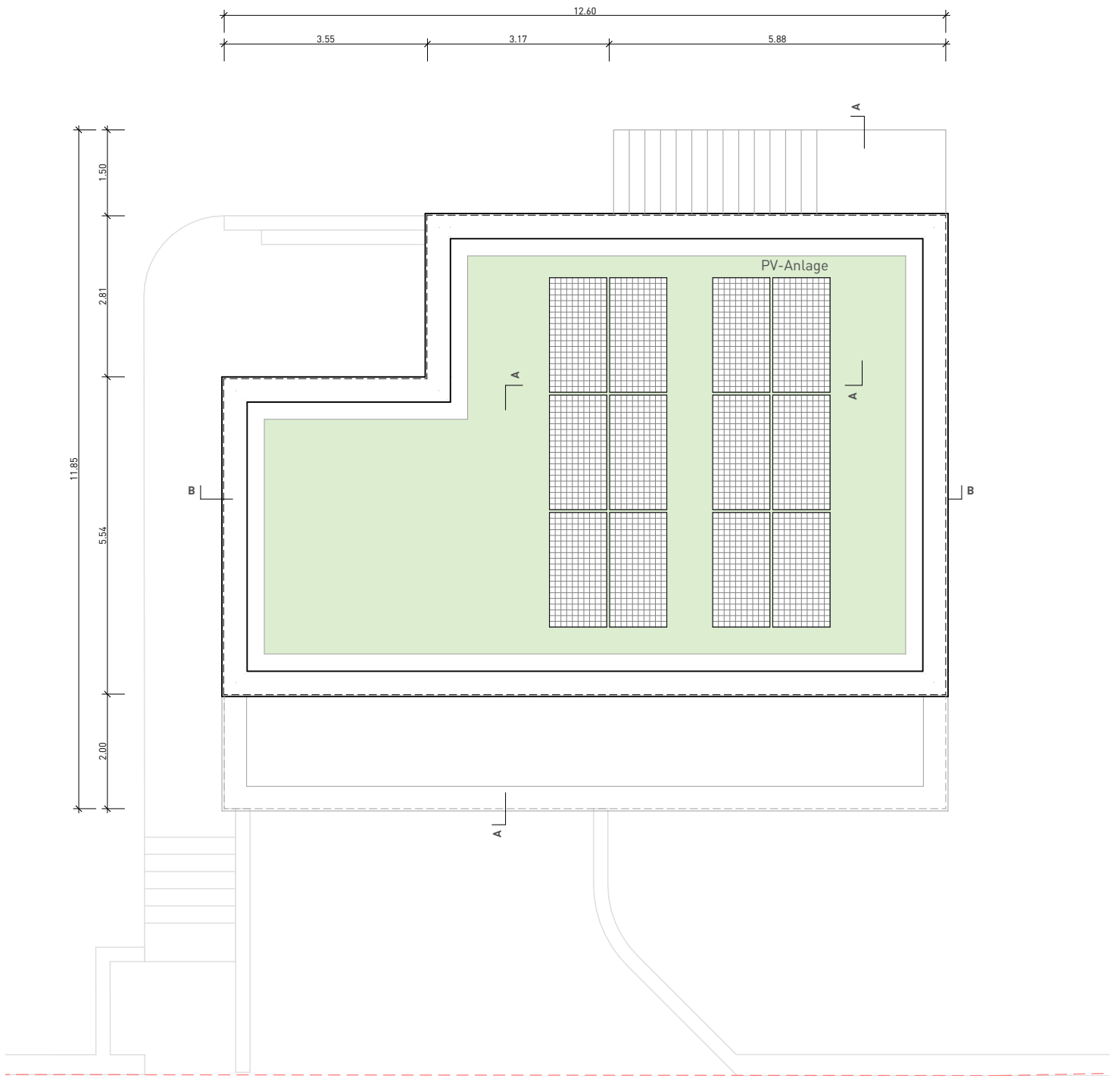

HAUS 1 | BODENWEG 60
 HAUS 2 | BODENWEG 62
 HAUS 3 | WALDSTRASSE 02

SWISSNESS INVEST AG HOLBEINSTRASSE 95 CH-4051 BASEL	
PROPLANING AG TÜRKHEIMERSTRASSE 6 PF CH-4009 BASEL	
VERKAUF IMMOFFICE, HOLBEINSTRASSE 95 CH-4051 BASEL	
1306-00-3 BOD PARZELLE 1603 BODENWEG 60 CH-4144 ARLESHEIM	
NEUBAU, DREI EFH HAUS 1	
DACHAUFSICHT	
1:100	A4
H1.006	07.11.2025

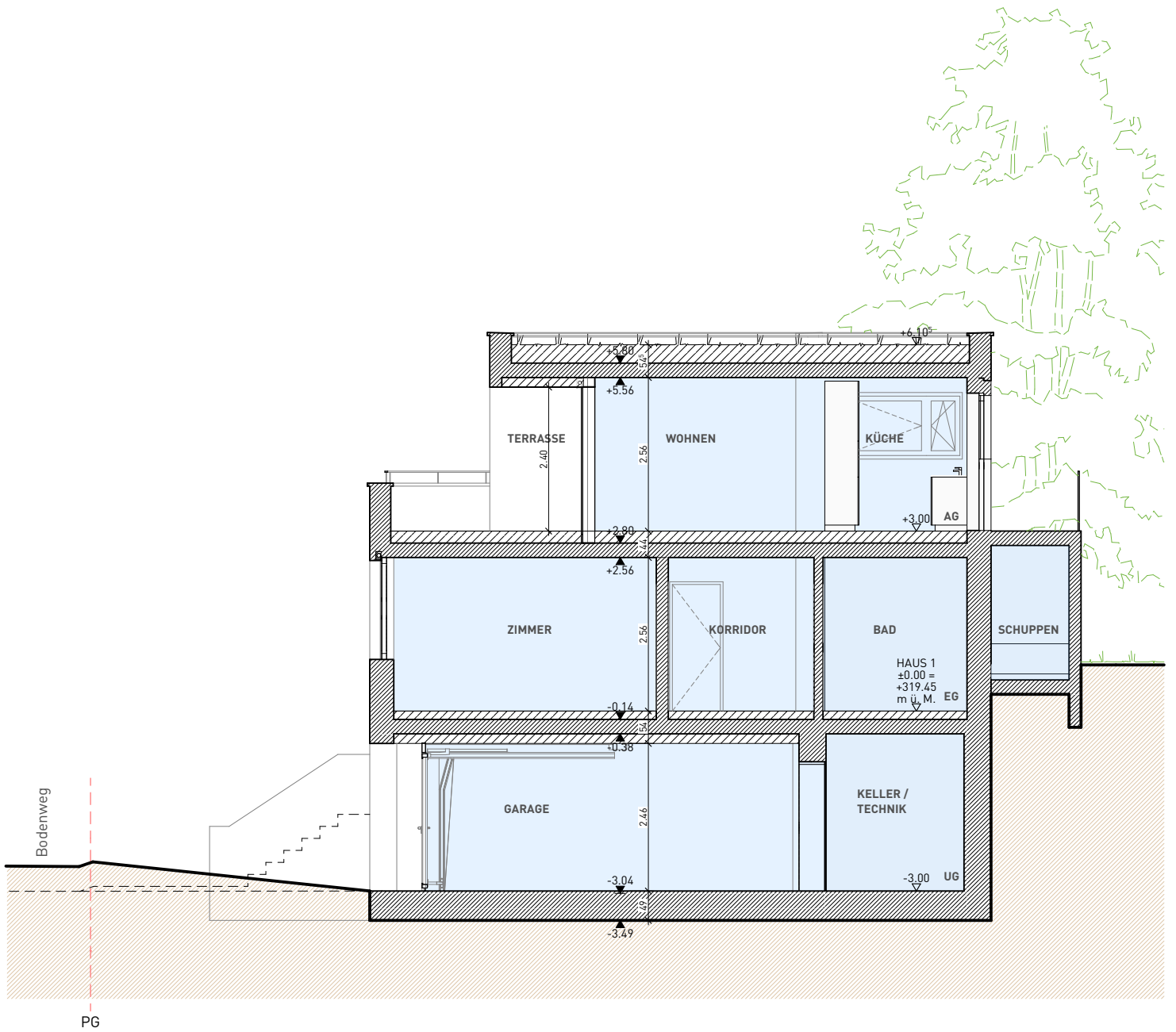

HAUS 1 | BODENWEG 60
 HAUS 2 | BODENWEG 62
 HAUS 3 | WALDSTRASSE 02

SWISSNESS INVEST AG HOLBEINSTRASSE 95 CH-4051 BASEL	
PROPLANING AG TÜRKHEIMERSTRASSE 6 PF CH-4009 BASEL	
VERKAUF IMMOFFICE, HOLBEINSTRASSE 95 CH-4051 BASEL	
1306-00-3 BOD PARZELLE 1603 BODENWEG 60 CH-4144 ARLESHEIM	
NEUBAU, DREI EFH HAUS 1	
SCHNITT A-A	
1:100	A4
H1.007	07.11.2025

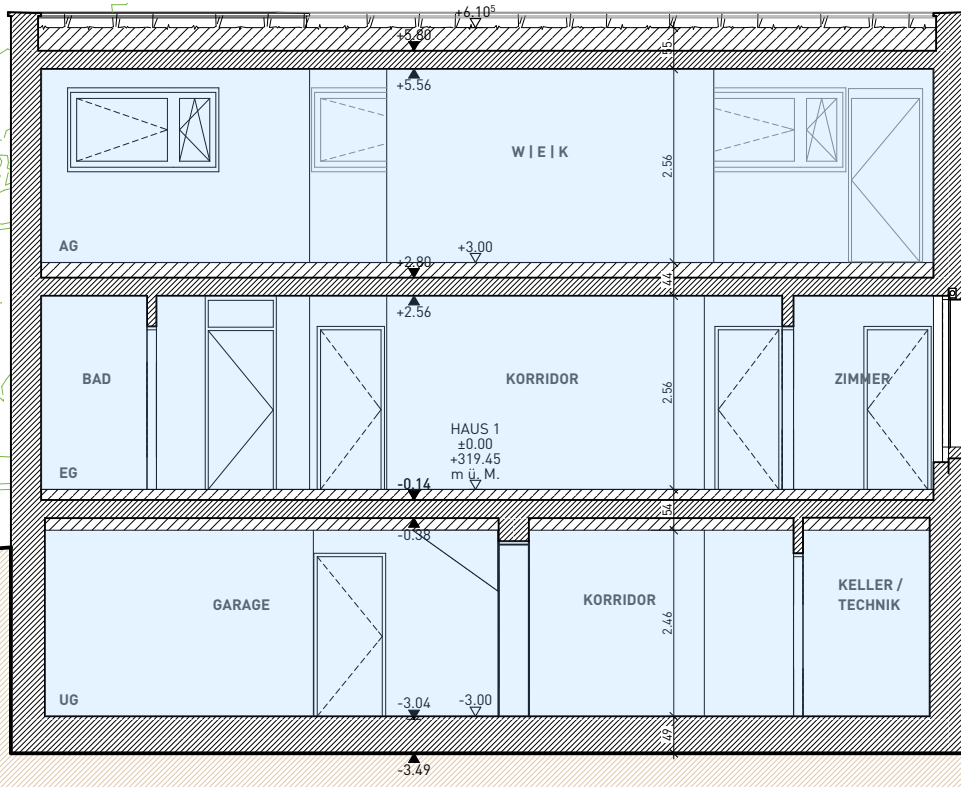
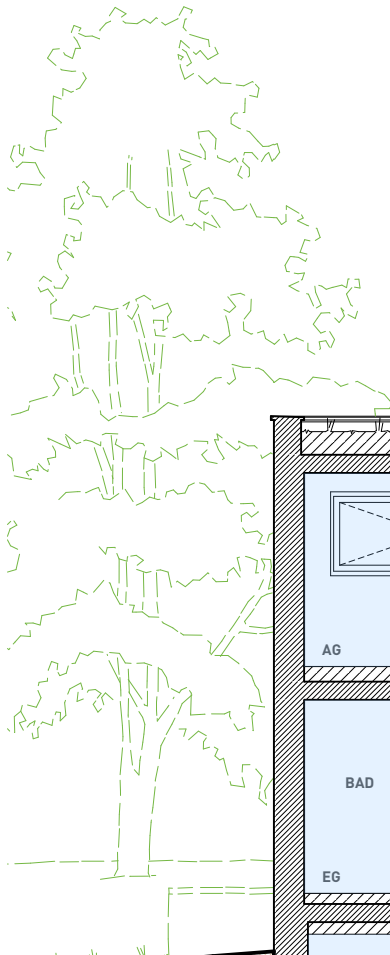

PG



HAUS 1 | BODENWEG 60
 HAUS 2 | BODENWEG 62
 HAUS 3 | WALDSTRASSE 02

SWISSNESS INVEST AG HOLBEINSTRASSE 95 CH-4051 BASEL	
PROPLANING AG TÜRKHEIMERSTRASSE 6 PF CH-4009 BASEL	
VERKAUF IMMOOFFICE, HOLBEINSTRASSE 95 CH-4051 BASEL	
1306-00-3 BOD PARZELLE 1603 BODENWEG 60 CH-4144 ARLESHEIM	
NEUBAU, DREI EFH HAUS 1	
SCHNITT B-B	
1:100	A4
H1.008	07.11.2025

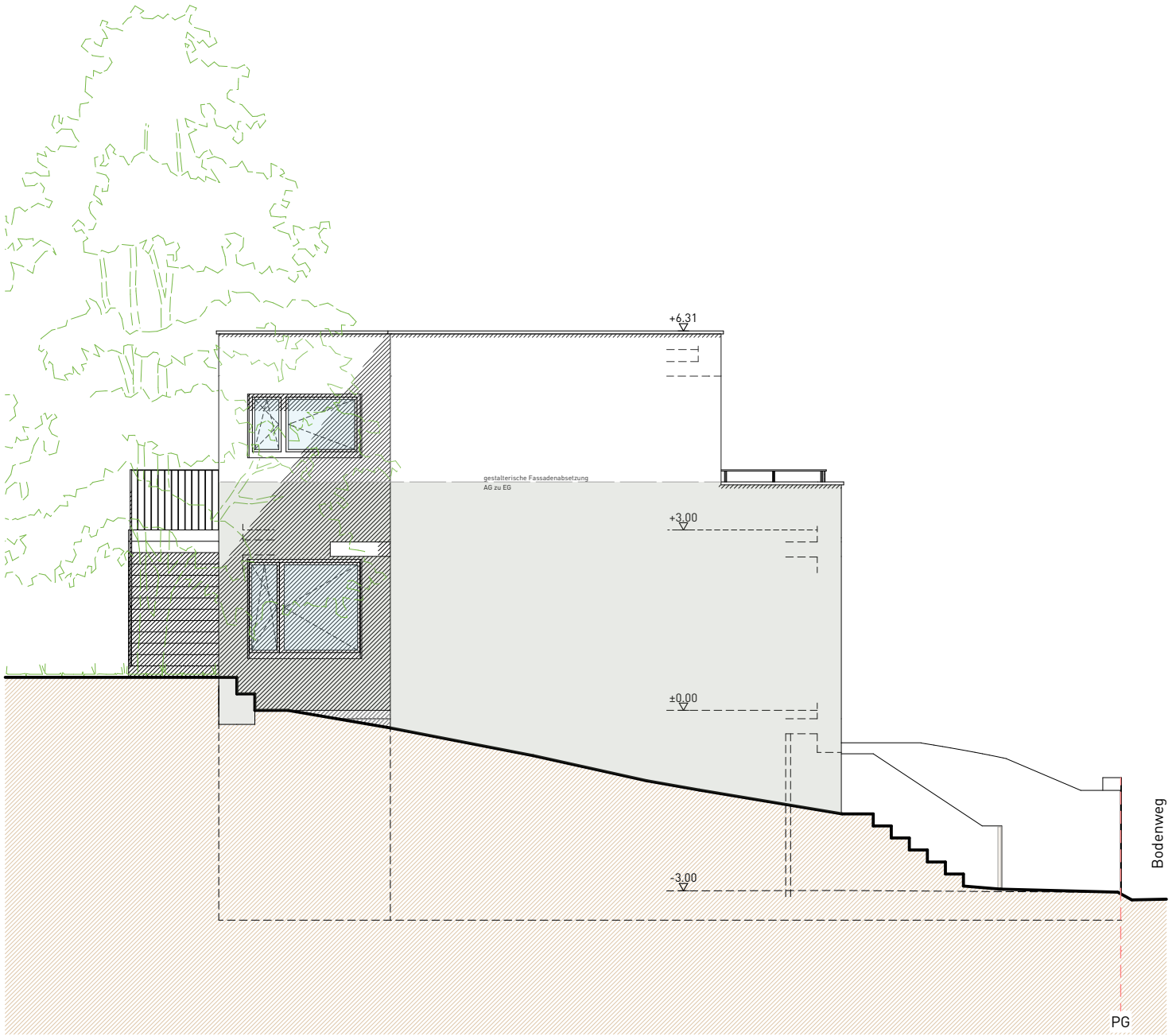

HAUS 1 | BODENWEG 60
 HAUS 2 | BODENWEG 62
 HAUS 3 | WALDSTRASSE 02

SWISSNESS INVEST AG HOLBEINSTRASSE 95 CH-4051 BASEL	
PROPLANING AG TÜRKHEIMERSTRASSE 6 PF CH-4009 BASEL	
VERKAUF IMMOOFFICE, HOLBEINSTRASSE 95 CH-4051 BASEL	
1306-00-3 BOD PARZELLE 1603 BODENWEG 60 CH-4144 ARLESHEIM	
NEUBAU, DREI EFH HAUS 1	
ANSICHT NORD	
1:100	A4
H1.009	07.11.2025

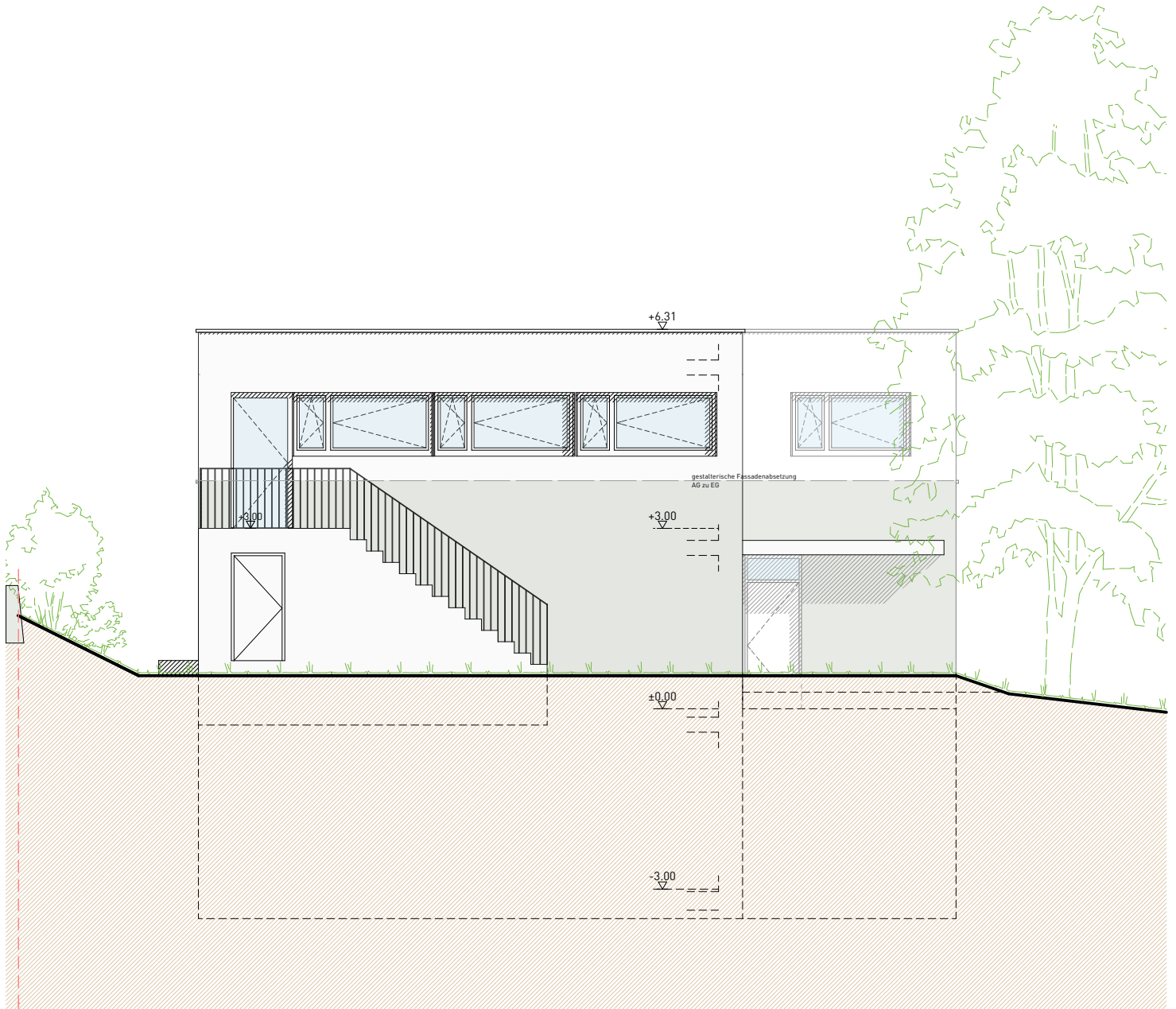

PG



HAUS 1 | BODENWEG 60
 HAUS 2 | BODENWEG 62
 HAUS 3 | WALDSTRASSE 02

SWISSNESS INVEST AG HOLBEINSTRASSE 95 CH-4051 BASEL	
PROPLANING AG TÜRKHEIMERSTRASSE 6 PF CH-4009 BASEL	
VERKAUF IMMOFFICE, HOLBEINSTRASSE 95 CH-4051 BASEL	
1306-00-3 BOD PARZELLE 1603 BODENWEG 60 CH-4144 ARLESHEIM	
NEUBAU, DREI EFH HAUS 1	
ANSICHT OST	
1:100	A4
H1.010	07.11.2025

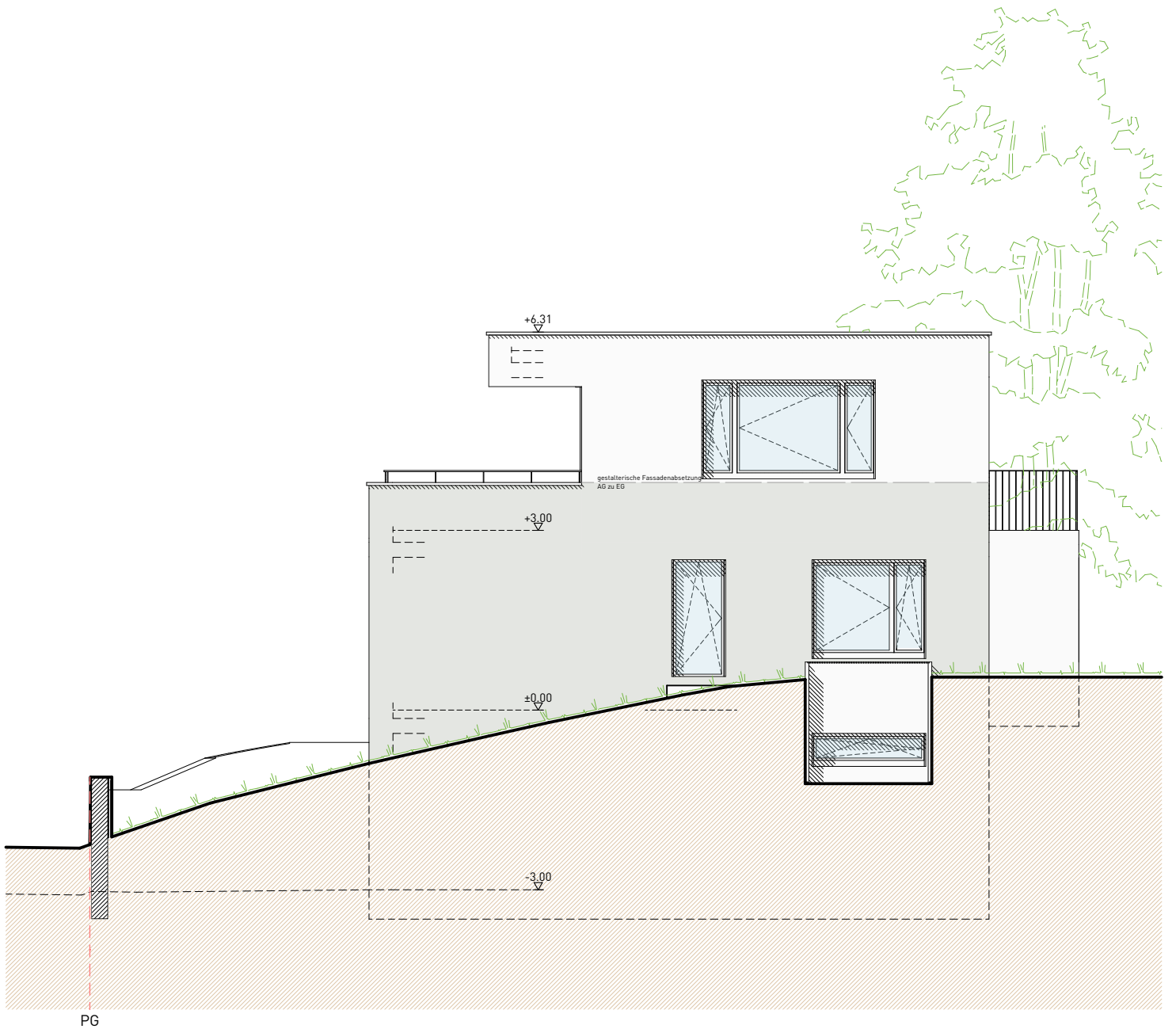

HAUS 1 | BODENWEG 60
 HAUS 2 | BODENWEG 62
 HAUS 3 | WALDSTRASSE 02

SWISSNESS INVEST AG HOLBEINSTRASSE 95 CH-4051 BASEL	
PROPLANING AG TÜRKHEIMERSTRASSE 6 PF CH-4009 BASEL	
VERKAUF IMMOOFFICE, HOLBEINSTRASSE 95 CH-4051 BASEL	
1306-00-3 BOD PARZELLE 1603 BODENWEG 60 CH-4144 ARLESHEIM	
NEUBAU, DREI EFH HAUS 1	
ANSICHT SÜD	
1:100	A4
H1.011	07.11.2025



HAUS 1 | BODENWEG 60
 HAUS 2 | BODENWEG 62
 HAUS 3 | WALDSTRASSE 02

SWISSNESS INVEST AG HOLBEINSTRASSE 95 CH-4051 BASEL	
PROPLANING AG TÜRKHEIMERSTRASSE 6 PF CH-4009 BASEL	
VERKAUF IMMOFFICE, HOLBEINSTRASSE 95 CH-4051 BASEL	
1306-00-3 BOD PARZELLE 1603 BODENWEG 60 CH-4144 ARLESHEIM	
NEUBAU, DREI EFH HAUS 1	
ANSICHT WEST	
1:100	A4
H1.012	07.11.2025